

Product Manual



Lithium Ferro Phosphate (LFP) Battery 48V 30Ah N70 Plastic Cased Battery



Part Number GC48V-030AH-C

LFP Battery GC48V-30AH-C – Product Manual

Contents

1	INTRODUCTION	3
2	GENERAL INFORMATION	3
2.1	LIFE SUPPORT POLICY	3
2.2	GENZ ENERGY PTY LTD	3
3	SAFETY GUIDELINES	4
3.1	WEIGHT	4
3.2	RISK OF ELECTRIC SHOCK	4
3.3	STORED ENERGY	4
3.4	COMPETENT SERVICE PERSONNEL ONLY	4
3.5	MATERIAL SAFETY DATA SHEET (MSDS)	4
4	SPECIFICATIONS	5
5	BATTERY OVERVIEW	6
5.1	BATTERY MANAGEMENT SYSTEM (BMS)	6
5.2	TERMINALS, POSITIVE AND NEGATIVE	6
6	INSTALLATION	6
6.1	RECEIVING INFORMATION	6
6.2	INSTALLATION PLACEMENT	7
6.3	CHARGER	7
6.4	USE OF A SINGLE BATTERY	7
6.5	PARALLEL CONNECTION OF BATTERIES	7
6.6	SERIES CONNECTION	8
6.7	INSTALLATION OF THE BATTERY	8
6.8	CONNECTING TO THE TERMINALS	9
6.9	TERMINAL PROTECTION	9
6.10	VENTILATION	9
6.11	BATTERY MAINTENANCE	9
6.12	CHARGING THE BATTERY	10
6.13	DISCHARGING THE BATTERY	10
6.14	STORAGE	11
7	TROUBLE SHOOTING	12
8	WARRANTY & SERVICE INFORMATION	13
8.1	RECORD OF PURCHASE	13
8.2	BEFORE CALLING FOR SERVICE	13
8.3	WARRANTY OR SERVICE	13
9	APPENDIX C – DIMENSIONS	14

LFP Battery GC48V-30AH-C – Product Manual

1 Introduction

Thank you for purchasing this Lithium Ferro Phosphate (LFP) Battery. It has been designed and manufactured to provide many years of trouble free service.

Please read this manual prior to installing the Lithium Ferro Phosphate (LFP) Battery. This product manual covers the following Battery model:

- GC48V-030AH-C

This manual provides important information that must be followed during installation, commissioning and maintenance of the Battery. Failure to follow these instructions may lead to you damaging the system it is being installed into and/or voiding your warranty. There are important safety and handling procedures that must be followed for your own safety and the safety of those around you.

This manual also contains information for customer support and factory service if it is required.

2 General Information

2.1 Life Support Policy

We do not recommend the use of this battery in 'life support' applications where failure or malfunction of the battery can be reasonably expected to cause failure of the life support device or to significantly affect its safety or effectiveness.

2.2 genZ Energy Pty Ltd

All Rights Reserved.

All rights of this User Manual ("Manual"), including but not limited to the content, information, and figures are solely owned and reserved by genZ Energy PTY LTD. ("genZ Energy"). The Manual can only be applied to the operation or the use of this product. Any disposition, duplication, dissemination, reproduction, modification, translation, extraction, or usage of this manual in whole or in part is prohibited without the prior written permission of genZ Energy. Given that genZ Energy will continuously improve and develop the product, changes may be made to the information in this Manual at any time without obligation to notify any person of such revision or change. genZ Energy will make all possible efforts to secure the accuracy and the integrity of this manual. genZ Energy disclaims any kind or forms of warranty, guarantee, or undertaking, either expressly or implicitly, including but not limited to the completeness, faultlessness, merchantability or fitness for a particular purpose of the manual.

LFP Battery GC48V-30AH-C – Product Manual

3 Safety Guidelines



3.1 Weight

The Battery is heavy. Any time the Battery has to be handled be sure to use appropriate manual handling techniques. This is particularly important where the battery maybe being installed in a confined space.

3.2 Risk of Electric Shock

While this battery is 48 Volts DC, the charger or inverter connected to this battery may be operating at mains AC voltages. Connecting any of our LFP batteries to any electrical system should only be carried out by suitably competent service personnel only.

3.3 Stored Energy

These Batteries can, especially if they are connected in parallel, produce high currents. Care should be taken to avoid shorting the terminals.

3.4 Competent Service Personnel Only

Battery replacement should be performed by competent service personnel only. This battery contains no user serviceable parts inside and is sealed.

3.5 Material Safety Data Sheet (MSDS)

Refer to the MSDS that was supplied with this battery in case of an accident.

LFP Battery GC48V-30AH-C – Product Manual

4 Specifications

Product Model		GC-48V-030AH-C	
Electrical Characteristics	Normal Voltage	51.2V DC	
	Rated Capacity	30±1Ah(0.2C)	
	Energy	Approx. 1536Wh	
	Internal Resistance	≤40mΩ	
	Cycle Life at 25°C constant (80% capacity remaining)		≥2,000@0.2C (100%DOD)
			≥6,000@0.2C (80%DOD)
			≥10,000@0.2C (50%DOD)
Self-Discharge	Approximately 14% per annum		
Battery Management System	Over charge protection, Over discharge protection, Over temperature protection, Internal Cell Balancing		
Standard Charge	Charge Voltage	57.6±0.15V	
	Charge Mode	Constant Current (0.2C) 6Amps to 57.6V, then Constant Voltage of 57.6V until charge current reaches (0.01C) 1Amp (CC/CV)	
	Charge Current	6A (0.2C)	
	Max. Charge Current	15A (0.5C)	
Standard Discharge	Continuous Current	15A	
	Max Continuous Current	≤50A(≤5min)	
	Max. Pulse Current	≤150A±30A(≤1s)	
	Discharge Cut-off Voltage	Approximately 40.0V	
++Environmental	Charge Temperature	0°C to 45°C	
	Discharge Temperature	-20°C to 60°C	
	Battery Chemistry	Lithium Ferro Phosphate, LiFePO4 or LFP	
	UN Type Number (chemistry)	UN 3480	
	Storage Temperature	0°C to 40°C	
	IP Rating	52	
	Humidity	< 90%	
	Material of Case	Plastic	
	Dimensions (mm)	(326±2)mm×(170±2)mm×(210±2)mm	
	Weight	14.2±0.2kg	
	Certifications	See genZ.com.au	
Battery Management System	Terminal	M8 Bolt	
	¹ Over-voltage cut-off	58.4V	
	Under-voltage cut-off	40V	
	Over-temperature cut-off	65°C	
	Short circuit protection	150±30A (20ms trip)	

Product design and specification subject to change or modification without notice - images for illustration only. E&OE.

¹The over voltage cut-out may vary from that stated. This is due to the fact that the BMS protects the internal cell string voltages ahead of overall pack voltage.

LFP Battery GC48V-30AH-C – Product Manual

5 Battery Overview

5.1 Battery Management System (BMS)

This battery is fitted with (contained within the battery case) a sophisticated BMS. The BMS is designed to provide user safety and protect the battery cells from:

- Over voltage charging.
- Under voltage discharging.
- Operation beyond a safe temperature.
- Short circuit protection.

Should the BMS activate to protect the battery, the BMS will automatically reset once a normal operational condition is detected by the BMS.

5.2 Terminals, Positive and Negative

The battery terminals comprise of two M8 brass inserts. The positive terminal (+) is red and the negative terminal (-) is black. They are also marked with the + and the – symbols.

The battery is supplied with two M8 bolts.

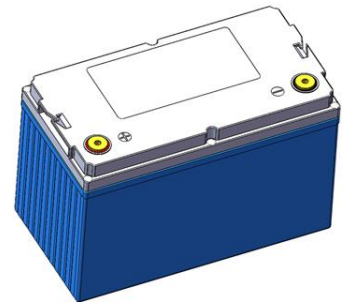

6 Installation



Failure to follow these guidelines will void the limited warranty and cause potential damage to property or serious injury.

6.1 Receiving Information

Once you receive the product it should be visually inspected for damage that may have occurred during shipping. Immediately notify the carrier and place of purchase if any damage is observed. The packing materials that the product was shipped has been designed to minimize any shipping damage. In the unlikely event that the product needs to be returned to the manufacturer, use the original packing material. Since the manufacturer is not responsible for shipping damage incurred when the product is returned, the original packing material is inexpensive insurance.

LFP Battery GC48V-30AH-C – Product Manual

6.2 Installation Placement



The Battery must be installed such that it is not exposed to:

- Sources of radiant heat.
- Extreme cold where the ambient temperature is expected to regularly fall below -10°C.
- Direct and prolonged sunlight.
- Direct and prolonged rain or places where it can become submerged in water.
- Corrosive and explosive atmospheres.

6.3 Charger

While there are a number of chargers that should work with this battery, it is recommended that chargers that comply with the LFP batteries charge profile are used.

It should be noted that should the LFP battery be discharged to the point where the batteries BMS reaches the low voltage cut off limit, some battery chargers will NOT then charge the battery. To overcome this, the charger should be placed into 'power supply' (48V/51.2V) mode (if available) and allowed to charge the battery until a terminal voltage greater than 51.2 Volts is observed at the battery terminal.

6.4 Use of a Single Battery

Ensure that the following is considered prior to installing:

- Use only good quality cable lugs that are of the size suitable to accommodate the M8 terminal bolts.
- The correct size of cable to the battery connector is used.
- That the polarity of the connection is observed. + and – symbols are clearly marked on both the terminals along with the colour of Red for positive and black for negative.

6.5 Parallel Connection of Batteries

In addition to the guidelines for a single module, when connecting in parallel, the following additional considerations apply:

- As the connection of these modules in parallel can result in high currents and stored energy, the design of such a system should be made by a competent person or persons only.
- All Batteries should be fully charged prior to installation as the batteries may have different states/levels of charge. Refer to the "Charging the Battery" section of this manual for charging guidelines.

LFP Battery GC48V-30AH-C – Product Manual

- Do NOT install a fully discharged Battery into a fully charged bank of batteries.
- Do NOT install a fully charged Battery into a fully discharged bank of batteries.
- Do NOT mix these Batteries with other battery chemistry types without prior engineered testing.
- Do NOT mix these Batteries with LFP batteries from other manufacturers.
- Consider the use of a suitable fuse(s) to protect from the very high currents that can be achieved when these batteries are connected in parallel.
- Parallel connections involve connecting the POSITIVE (+) connection of one battery to the POSITIVE (+) connection of the next battery. The same goes for the negative side; NEGATIVE (-) of the first battery connects to the NEGATIVE (-) of the next battery. Please refer to the below image for suggested connection. This will help balance the current flow.

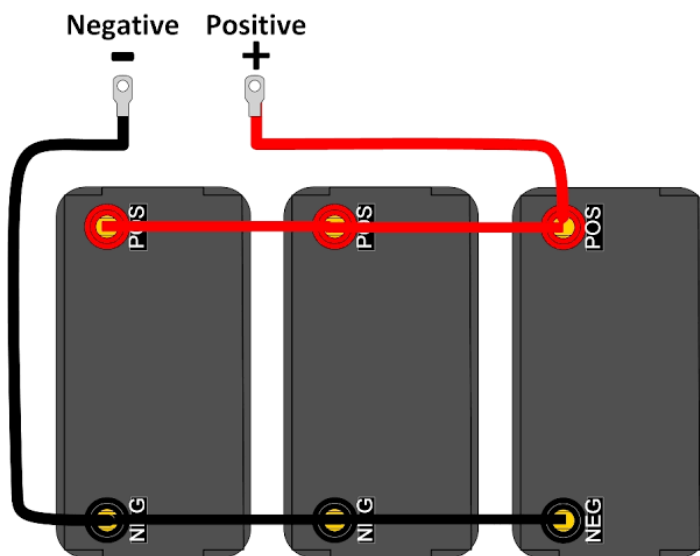

6.6 Series Connection

These Batteries are NOT designed for connecting in series. Connecting in series will void your warranty.

6.7 Installation of the Battery

Be sure to read the installation placement and associated cautions before installing the Battery.

Select a location, which will provide good air circulation for the Battery. Route cables so they cannot be walked on, pinched or damaged in any way.

Where the battery is to be used in a mobile application, ensure that a suitable hold down clamp is used to prevent the battery moving or vibrating.

These Batteries can be used in any orientation EXCEPT upside down. Upside down is where the terminals are facing downwards.

Place the Battery in the final desired location and complete the rest of the installation procedure.

LFP Battery GC48V-30AH-C – Product Manual

6.8 Connecting to the Terminals

NOTE: If this battery is to be used where it may receive occasional splashes of water or located in extremely humid conditions, the use of a small amount of plumbers liquid thread seal around the M8 bolts thread prior to them being inserted must be applied.

If using flat washers, it is very important to ensure the battery cable lug connection is contacting the brass surface of the terminal, and the washer is placed on top of the cable lug connection. Do not place washer between the battery terminal and the battery wire as this creates high resistance and can cause the terminal to overheat and fail.

It is important that fasteners be tightened to the appropriate torque of 10 – 11 Nm or 85 – 95 in-lbs

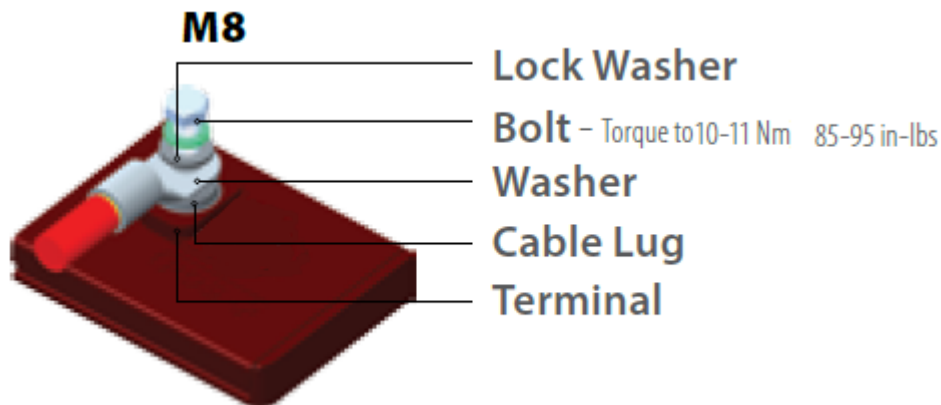

6.9 Terminal Protection

While LFP batteries will not present with the same type of corrosion that is seen when lead acid batteries are used, corrosion can still occur on terminals if they are not kept clean and dry. To prevent corrosion, after tightening the M8 bolt, apply a thin coat of terminal protector spray that can be purchased through your local battery dealer.

6.10 Ventilation

Unlike deep-cycle flooded/wet lead acid batteries which release small amounts of gas during usage, particularly during the charging process, LFP batteries do not release these harmful and potentially explosive gases. However, some form of ventilation is still recommended.

6.11 Battery Maintenance

LFP batteries do not require any checking of the battery internals.

The LFP battery is essentially 'maintenance free' and no attempt should be made to open the plastic case. Doing so will void any warranty and may lead to a potentially dangerous short circuit situation.

LFP Battery GC48V-30AH-C – Product Manual

However, depending on the environment and type of use the LFP battery has, the following is recommended:

1. Examine the outside appearance of the battery, particularly the top of the battery and terminal connections. They should be clean and dry, as well as free of dirt and corrosion. Refer to Cleaning Section if cleaning is required.
2. Check battery cables and connections. Replace any damaged cables and tighten any loose connections. Refer to Torque Values.
3. Reapply anticorrosion spray if required.

6.12 Charging the Battery

Ideally these batteries should only be charged by a charger that is designed to charge LFP chemistry, at the correct voltage, current and charge profile.

The charging profile described below is designed to achieve **maximum number of cycles/life** of the Battery.

6.12.1 Ambient temperature of 20C

An ambient temperature of 20 Celsius is the ideal temperature for the operation of the battery.

6.12.2 Commence a charge cycle where the current is limited (Constant Current or CC) at 0.2C

0.2C is equal to 6 Amps for model GC48V-30AH-C.

6.12.3 Hold Voltage at 57.6 Volts for 2 hours

Charge the Battery at a Constant Current at a maximum of 6 Amps until the battery voltage reaches 57.6 Volts DC.

Continue charging at a constant voltage of 57.6 Volts for one (1) hour or until the charge current drops to less than 0.5 Amps. This will then allow the battery internal cells to 'balance' their terminal voltage.

6.12.4 Remove charge voltage

After two hours or when the charge current drops to less than 1 Amp, the charging voltage can be removed (or placed onto a float charge) as the battery should now be fully charged.

6.12.5 Float charge at 54.4 to 55.2 Volts

At the completion of the above charge profile, the battery can either be stored or placed on a float charge of 54.4 to 55.2 Volts. The lower of these two voltages will increase the life of the battery, but, provide a slightly reduced capacity. Floating at 55.2V will provide maximum capacity.

6.13 Discharging the Battery

The discharge characteristics described below are to achieve maximum number of cycles/life of the Battery.

LFP Battery GC48V-30AH-C – Product Manual

6.13.1 Battery discharge current

The ideal discharge current for the battery is 6 Amps, however, it should be noted that the battery can deliver up to 40 Amps (continuously) if required.

6.13.2 When to charge a discharged battery

While the Battery is protected by the BMS to prevent excessive battery discharge, it is recommended to recharge the battery as soon as practical (within 24 hours) following a discharge event, particularly if this has been to 100% DoD. This will ensure long life for your battery as well as providing a fully charged battery for when it is required.

6.14 Storage

The Battery should be stored, fully charged in an area that is protected from the elements and at an ideal temperature of 20C and low humidity. It should be stored in its original packing. The battery discharges at approximately 14% per annum. It is recommended that the battery be recharged every 6 months to maintain maximum life as well as a fully charged battery.

If storing a battery for an extended period of time, reference should be made to the “Self Discharge” characteristics as indicated in the table of specifications.

It should also be noted that, a battery module that has been stored for an extended period of time may exhibit a loss of capacity when it is first placed into service. This ‘loss of capacity’ can normally be corrected by cycling the battery at least three times.

LFP Battery GC48V-30AH-C – Product Manual

7 Trouble shooting

SYMPTOM / FAULT	POSSIBLE CAUSE	POSSIBLE SOLUTION
NO OUTPUT VOLTAGE AT BATTERY TERMINALS	BMS UNDER VOLTAGE, IN PROTECTION MODE	RECHARGE THE BATTERY AND RECHECK FOR CORRECT OUTPUT VOLTAGE
	BMS OVERCURRENT, IN PROTECTION MODE	CHECK FOR SHORT CIRCUITS OR EXCESSIVE CURRENT DRAW
	BMS OVER VOLTAGE, IN PROTECTION MODE	CHECK FOR CHARGING CIRCUIT SUPPLYING EXCESSIVE CHARGE VOLTAGE
	BMS OVER TEMPERATURE, IN PROTECTION MODE	CHECK AND INVESTIGATE REASON FOR HIGH TEMPERATURE
	OTHER	RETURN TO GENZ FOR SERVICE
SYMPTOM / FAULT	POSSIBLE CAUSE	POSSIBLE SOLUTION
BATTERY FAILING TO CHARGE OR HOLD CHARGE	INSUFFICIENT CHARGE VOLTAGE/CURRENT	CHECK FOR FAULTY CHARGER, POOR CABLING OR LOOSE CONNECTIONS
	SOLAR OR OTHER CHARGER NOT CONFIGURED CORRECTLY	REFER TO THE MANUFACTURER OF THE SOLAR OR MAINS CHARGER
	BATTERY CHARGER MAY WELL BE FAILING TO START A CHARGE CYCLE. THIS MAY OCCUR WITH SOME SMART CHARGERS THAT REQUIRE SEEING AT LEAST SOME VOLTAGE FROM A BATTERY	CHECK WITH CHARGER MANUFACTURER OR SUBSTITUTE THE CHARGER FOR A DIFFERENT TYPE OR USE A DC POWER SUPPLY SET TO THE CORRECT CHARGE VOLTAGE AND CURRENT
	OTHER	RETURN TO GENZ FOR SERVICE

LFP Battery GC48V-30AH-C – Product Manual

8 Warranty & Service Information

8.1 Record of Purchase

It is important that you maintain a record of your purchase details, the model number and serial number of the Battery.

8.2 Before Calling for Service

Verify that the charger and load are operating correctly. Refer to the “Trouble Shooting” section of this manual.

If you believe that the battery is not delivering it’s rated *capacity (refer to Specifications) the battery may be considered faulty if it fails to deliver less than 70% of it’s rated capacity during the warranty period.

*Note: Some chargers/inverters display the capacity of a battery module or the battery system. These calculated values can be inaccurate for a number of technical reasons and as such should not be relied on.

Refer to the genZ website at www.genz.com.au for full details of the warranty on this product.

8.3 Warranty or Service

In the unlikely event that you believe the battery is faulty, contact the place of purchase or the dealer/distributor first. If you cannot reach your dealer, or if they cannot resolve the issue please visit the genZ web site at www.genz.com.au for contact details for technical support.

Please ensure that you have the following information available:

- a) Where and when the battery was purchased.
- b) The model number.
- c) Serial number of your battery.
- d) Information on the nature of the failure.

<http://www.genz.com.au>

LFP Battery GC48V-30AH-C – Product Manual

9 Appendix C – Dimensions

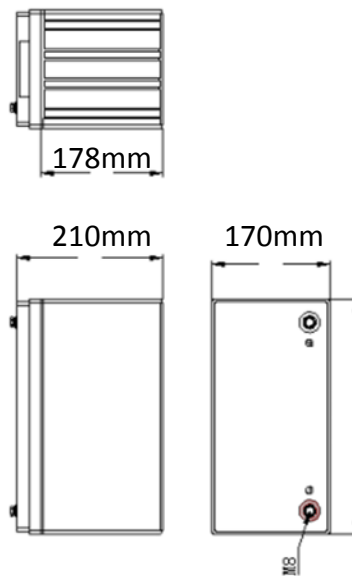
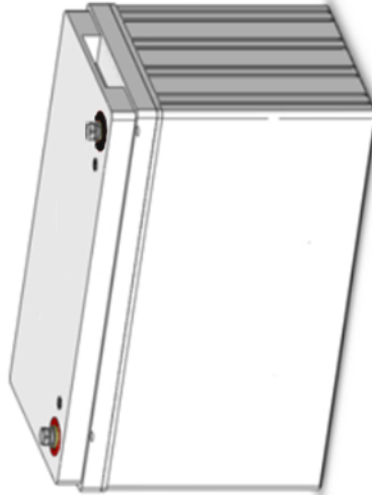



genZ Energy Pty Ltd

Western Australia

Email: info@genz.com.au

Web: www.genz.com.au